

SONIC STERN DRIVE 100

HAND OR HYDRAULIC TILT

F.N.R.

FOR USE WITH:

- Petrol Engines up to 100HP
 - Diesel Engines 60HP
- Subject to torque limitations

REDUCTION RATIOS:

1.6 : 1

2 : 1

F.N.R. GEARS



- **POWER STEERING** for maximum manoeuvrability.
- **PARALLEL THRUST** for optimum speed and efficiency.
- **KICK UP** to clear under water obstructions, for safety and protection.
- **FULL TILT** for easy trailering and service.
- **SIMPLE 6 BOLT TRANSOM** installation. Template supplied.
- **ENGINE** input rotation LH or RH.
- **TRIM ADJUSTMENT**, 3 position.
- **STREAMLINE** underwater section.
- **MARINE GRADE** alloy casing.
- **NICKEL ALLOY GEARS.**
- **STAINLESS STEEL FASTENERS.**
- **DOUBLE OIL SEALS** (Prop shaft).
- **SACRIFICIAL ANODE** provision.

SONIC TRANSMISSION UNITS ARE DESIGNED WITH SERVICE IN MIND. THE RUGGED BUT REFINED CONSTRUCTION ENABLES COMPLETE OVERHAULS TO BE CARRIED OUT WITH MINIMUM TOOLS. A FACILITY NOT ALWAYS POSSIBLE WITH OTHER TYPES OF MASS PRODUCED DRIVES.

Due to continual development Sillette - Sonic Limited reserve the right to alter, modify or replace any specification or design feature without prior notice.



HYDRAULIC PUMPS & PISTON SETS for SONIC/Enfield Stern Drives and Cat-Drives



Standard hydraulic piston, pump and hose are suitable for fitting to all the Sonic Stern Drive Range, in addition they are available for many other applications.

Hand Hydraulic Pump, raises unit with 12 pumps of the lever
or
12V Electro Hydraulic Pump with switch control. Both use common lift cylinder, 1" Diameter - 3" Stroke.

TECHNICAL DETAILS

Engine models must be within HP/RPM Torque specifications for Sonic 100 and approved by Sillette Sonic Limited in writing prior to purchase.

Reduction Ratios 1.6 :1 or 2 :1

Forward - Neutral - Reverse Shift • Safety latch allows Kick-Up in forward, but locks down in reverse • Quick change LH or RH output rotation • All Steel Tiller Arm • Double sealed Prop Shaft • Maximum Prop Diameter 14" • Accepts Transom Angles 7° to 17° • Anodes fitted • Easy Fitting, Full Instructions • Approximate dry weight 99lbs (45kg)

Max. Power

100hp C.V. PS. PK. @ 5000 rpm/upm.
PETROL SAE – 75kw
60hp C.V. PS. PK. @ 3600 rpm/upm.
DIESEL SAE – 45kw

Max. Input Torque Reduction Ratios

15kg/mtr - 110lbs/ft SAE 1.6 : 1 Ratio
12kg/mtr - 88lbs/ft SAE 2 : 1 Ratio
(reduced by 10% for commercial use)

Ahead - Neutral - Astern, Gearbox
Maximum tickover 800rpm/upm/rotations

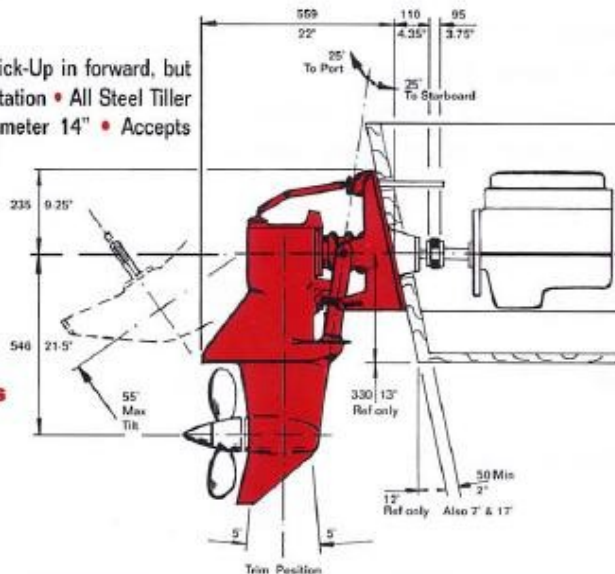

ENGINE ADAPTORS AND FLEXIBLE COUPLINGS



ENGINE RANGE

Yanmar	3JH3, 4JH3	: 40 to 56hp
Lombardini	LDW1003, LDW1404, LDW1503, LDW2004	: 30 to 48hp
Beta	BD1005, BV1305, BV1505, BV1903, BV2203	: 28 to 50hp
Nanni	3.100HE, 4.150HE, 4.195HE, 4.220HE	: 10 to 40hp
Volvo	2040, MD22L, 2003T, MD22	: 38 to 57hp
Perkins	A108, M50, M60	: 45 to 60hp
Ford/Mermaid	1.8 Ltr	
Leyland	1.5, 1.8, 2.2 & 2.5	: 30 to 60hp

Adaption available for listed engines.
Marine Engines available from Sillette • For other possibilities check with Sillette.

An Extensive range of Propellers • Couplings Adaptors • Spare Parts • Morse Teleflex Controls • Marinizing & Fitting Out Equipment available • Worldwide Mail Order Service.

Also Available:
Sonic Sail Drives – 2 Models • Sonic Catamaran Drives – 4 Models
Hydrodrives for Racing Yachts • Onboard Service Kits/Tools