

IMPELLER

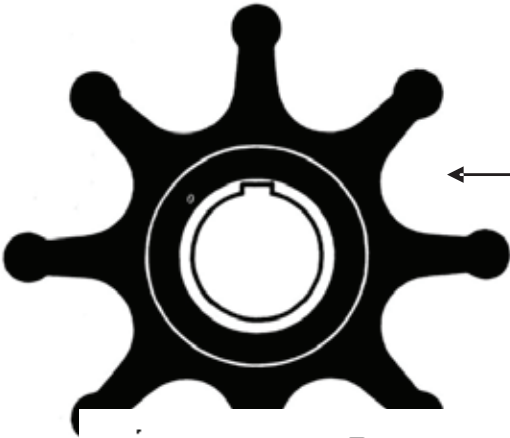

CW2036 De 65 - H 50.8 - Di 16 Neoprene  
 CW2050 De 65 - H 32.0 - Di 17 Neoprene  
 CW3379 De 65 - H 48.4 - Di 17 Neoprene  
 CW3407 De 65 - H 50.8 - Di 16 Nitrile  
 CW3410 De 65 - H 32.0 - Di 17 Nitrile

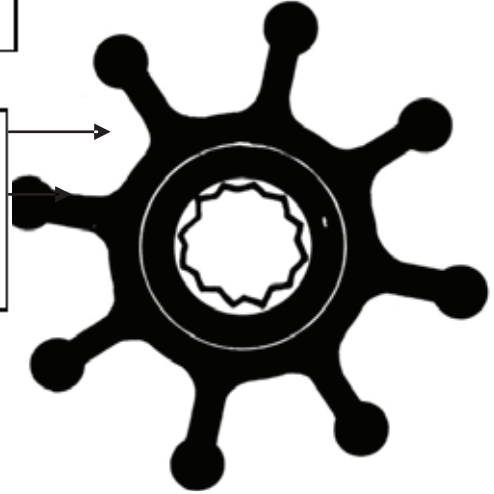

CW2039 De 65 - H 50.2 - Di 16 Neoprene  
 CW2077 De 65 - H 50.8 - Di 16 Nitrile  
 CW3260 De 65 - H 76.2 - Di 16 Neoprene  
 CW3388 De 65 - H 32.0 - Di 16 Neoprene  
 CW3509 De 65 - H 68.3 - Di 16 Neoprene  
 CW3408 De 65 - H 36.5 - Di 16 Neoprene

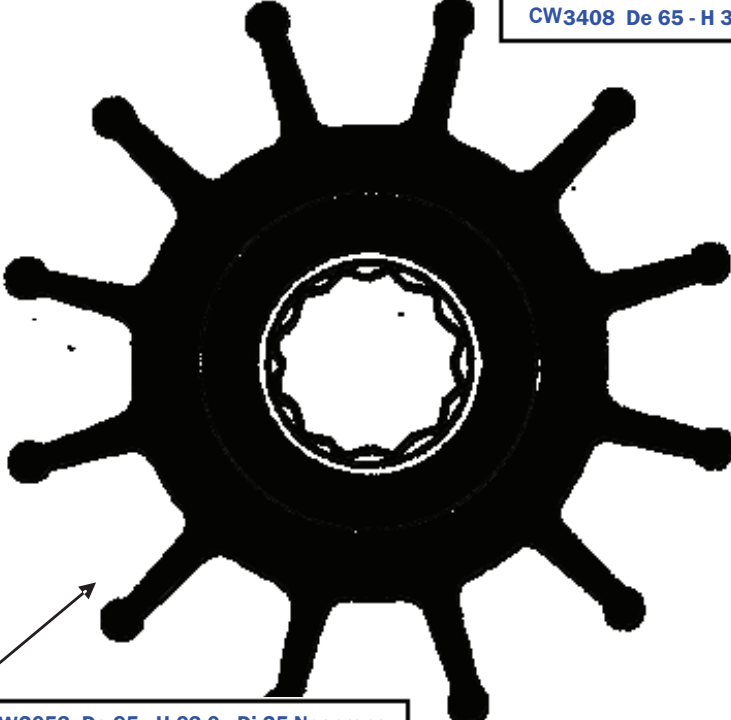

CW2053 De 95 - H 63.0 - Di 25 Neoprene  
 CW2054 De 95 - H 88.5 - Di 25 Neoprene  
 CW2718 De 95 - H 63.0 - Di 25 Nitrile  
 CW3261 De 95 - H 88.5 - Di 25 Nitrile  
 CW3315 De 95 - H 130 - Di 25 Neoprene  
 CW5641 De 95 - H 180 - Di 25 Neoprene

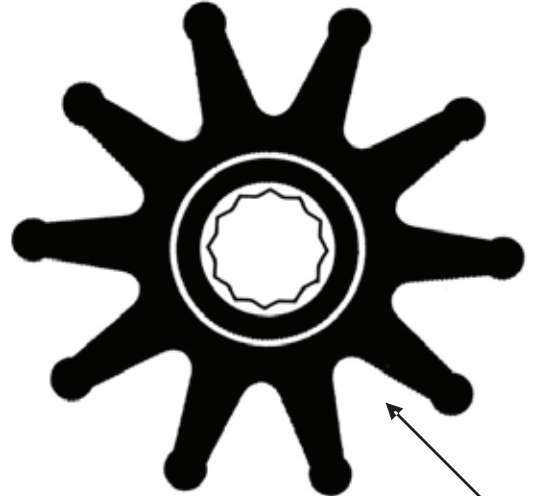

CW2042 De 65 - H 50.2 - Di 16 Neoprene  
 CW3405 De 65 - H 50.2 - Di 16 Nitrile

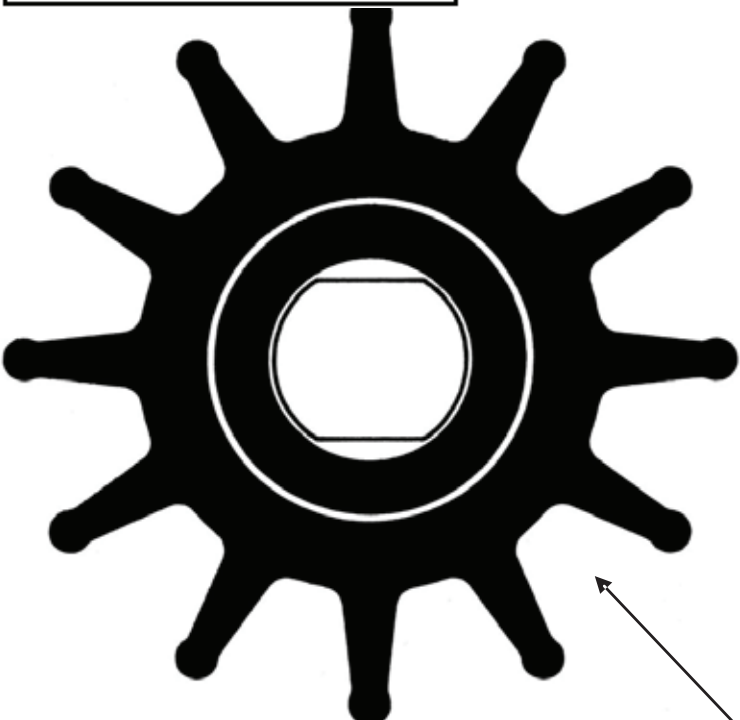

CW2654 De 95 - H 63.0 - Di 25 Neoprene  
 CW2655 De 95 - H 88.5 - Di 25 Neoprene

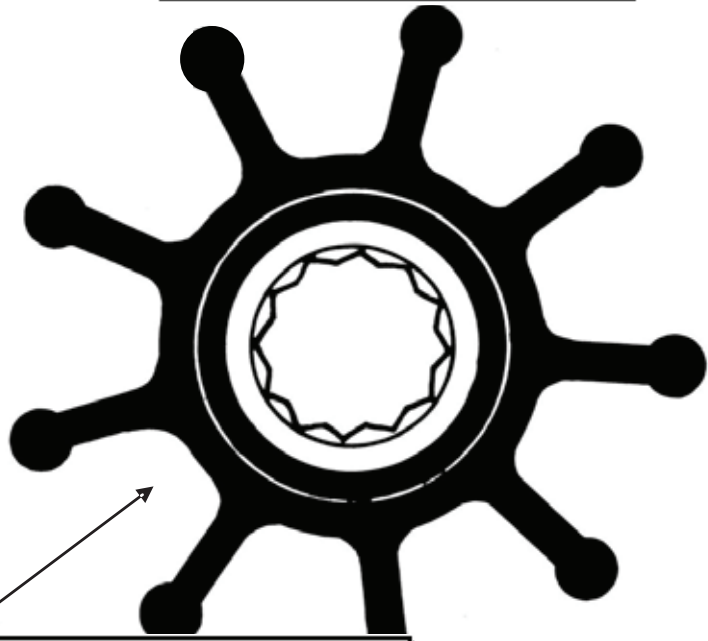

CW2038 De 95 - H 63.0 - Di 25 Neoprene  
 CW2045 De 95 - H 88.5 - Di 25 Neoprene  
 CW2717 De 95 - H 63.0 - Di 25 Nitrile  
 CW3406 De 95 - H 88.5 - Di 25 Nitrile  
 CW4915 De 95 - H 96 - Di 25 Neoprene  
 CW5953 De 95 - H 63.0 - Di 22 Neoprene

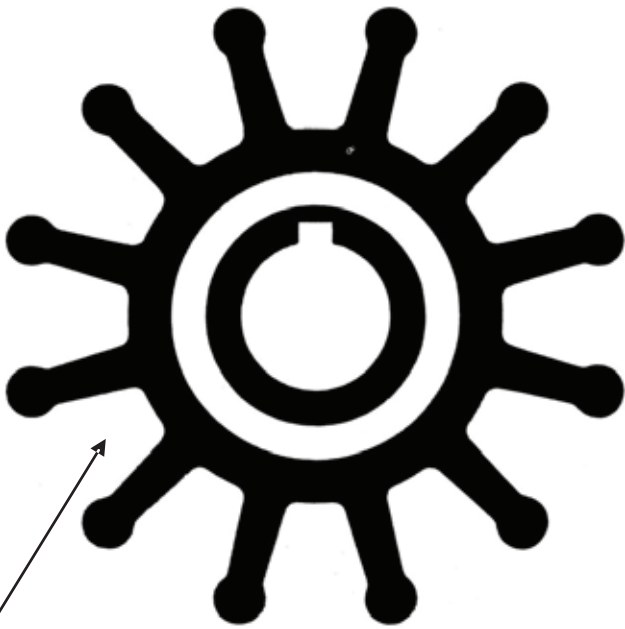

CW2672 De 82.5 - H 73.0 - Di 20.1 Neoprene

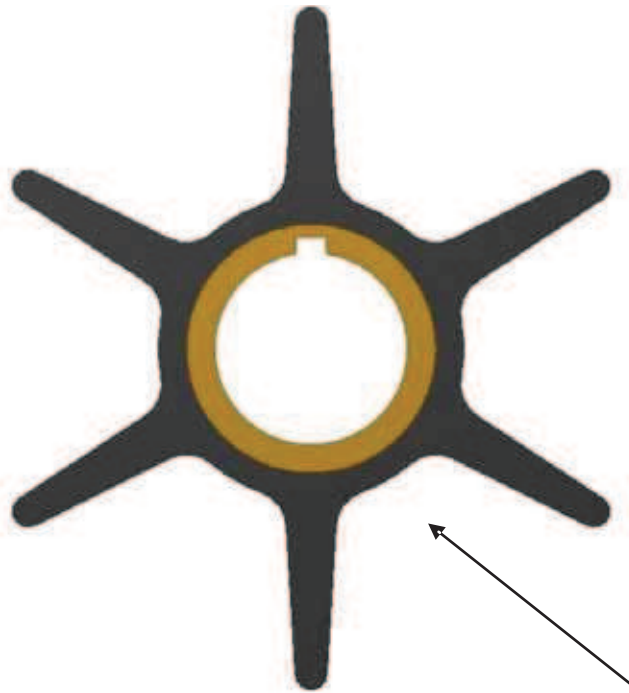

CW6003 De 90 - H 31,2 - Di 26 Neoprene



CW3386 De 65 - H 50.8 - Di 19 Neoprene

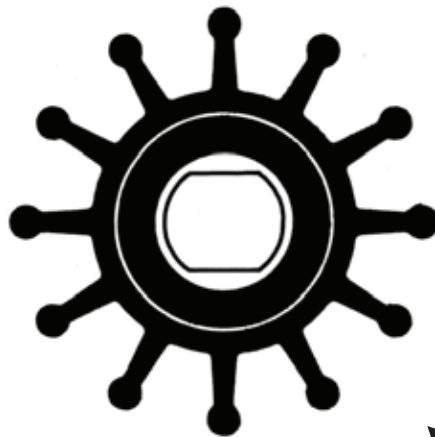

CW 3392 De 57 - H 31.7 - Di 16 Neoprene

CW2037 De 62 - H 31.5 - Di 16 Neoprene

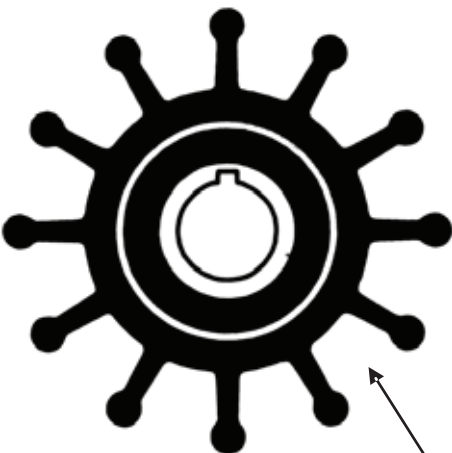

CW3950 De 57 - H 20 - Di 12.7 Neoprene

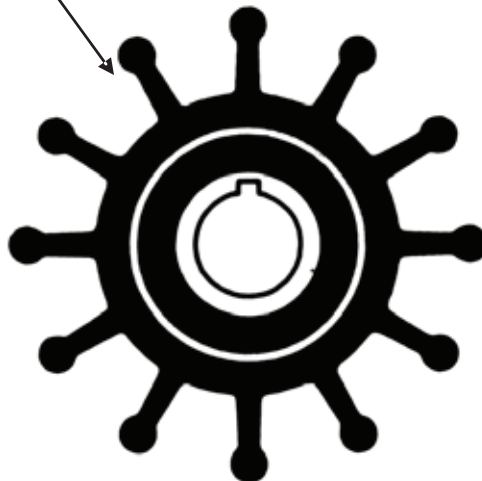

CW2052 De 51 - H 22 - Di 12.7 Neoprene  
 CW2745 De 51 - H 22 - Di 8.1 Neoprene  
 CW2080 De 51 - H 22 - Di 8.1 Nitrile

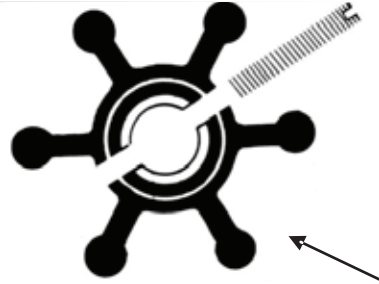

CW2043 De 40 - H 19 - Di 9.6 Neoprene  
 CW2048 De 40 - H 19 - Di 12 Neoprene  
 CW3268 De 40 - H 19 - Di 10 Neoprene  
 CW3404 De 40 - H 19 - Di 10 Nitrile

CW2049 De 51 - H 22 - Di 10 Neoprene  
 CW2051 De 51 - H 22 - Di 13 Neoprene  
 CW5435 De 51 - H 20 - Di 13 Neoprene  
 CW5550 De 51 - H 22 - Di 12.7 Neoprene

CW2079 De 45.7 - H 12.8 - Di 8.1 Nitrile

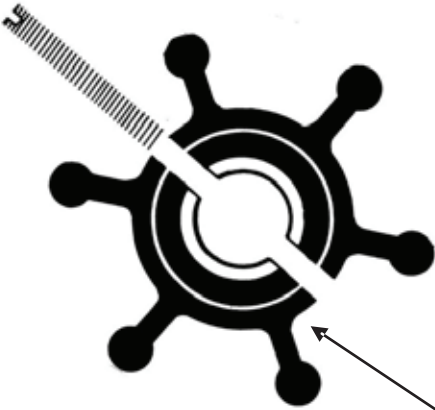

CW1872 De 40 - H 19 - Di 8.1 Neoprene

CW2522 De 51 - H 22 - Di 12 Neoprene  
 CW2046 De 51 - H 22 - Di 12.7 Neoprene  
 CW3411 De 51 - H 22 - Di 12 Nitrile  
 CW3269 De 51 - H 22 - Di 12.7 Nitrile  
 CW 5053 De 51 - H 22 - Di 12 Neoprene

CW536 De 32 - H 12.5 - Di 8.1 Nitrile  
 CW2044 De 32 - H 12 - Di 8.1 Neoprene  
 CW3852 De 32 - H 12 - Di 8.1 Nitrile

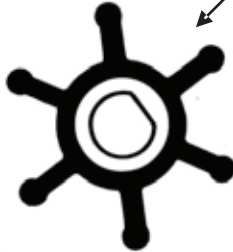
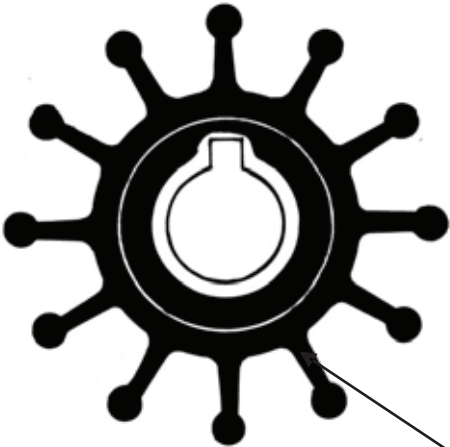

CW2041 De 57 - H 31.7 - Di 16 Neoprene  
 CW2081 De 56 - H 29.0 - Di 12 Nitrile  
 CW3342 De 56 - H 29.0 - Di 12 Neoprene  
 CW3403 De 57 - H 31.7 - Di 16 Nitrile  
 CW3414 De 57 - H 31.7 - Di 20 Nitrile

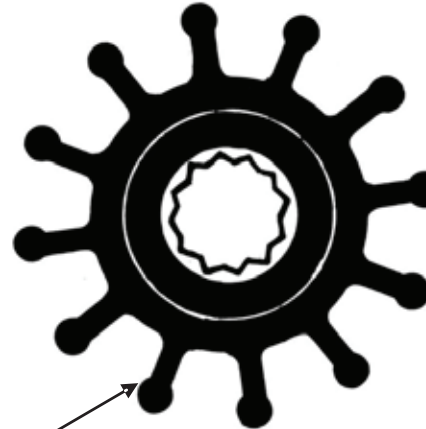

CW2040 De 57 - H 31.7 - Di 16 Neoprene  
 CW2078 De 57 - H 31.7 - Di 16 Nitrile  
 CW2789 De 57 - H 50.8 - Di 16 Neoprene  
 CW3267 De 57 - H 48.2 - Di 16 Neoprene

CW3790 De 65 - H 50.8 - Di 16 Neoprene  
 CW2047 De 65 - H 41.4 - Di 16 Neoprene  
 CW4821 De 65 - H 41.4 - Di 16 Neoprene

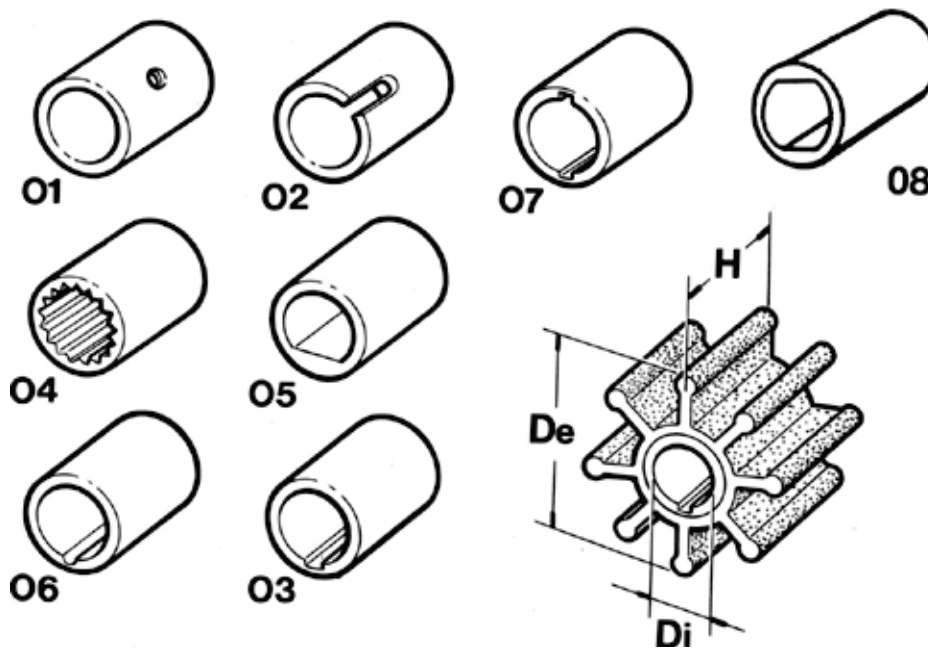

### EQUIVALENTENLIJST IMPELLERS

Jabsco / Johnson			
Clouds ref.	Materiaal	Jabsco ref.	Johnson ref.
2036	Neopreen	4598-0001	
2037	Neopreen	18838-0001	
2038	Neopreen	836-0001	09-1029B
2039	Neopreen	920-0001 17937-0003	09-1028B
2040	Neopreen	1210-0001	09-1027B
2041	Neopreen	4568-0001	09-801B
2042	Neopreen	920-0001 17937-0001	09-1028B
2043	Nitrile	4528-0001	09-806B
2044	Neopreen	21414-0001	
2045	Neopreen	6760-0001	09-802B
2046	Neopreen	673-0001	09-1026B
2047	Neopreen	18948-0001	
2048	Neopreen	22405-0001	09-808B
2051	Neopreen	22799-0001	
2054	Neopreen	17936-0001	09-802B/09-814B
2078	Nitrile	1210-0003 17937-0003	09-1027B-9
2080	Nitrile	6303-0003	09-824 P-9
2522	Neopreen	653-0001	09-810B
2672	Neopreen	18958-0001	
2717	Nitrile	836-0003	09-1029B-9
2718	Nitrile	17935-0003	09-819B-9
3267	Neopreen	13554-0001	09-812B
3386	Neopreen	17954-0001	
3407	Nitrile	500202	
3790	Neopreen	18327-0001	

SHERWOOD		
Clouds ref.	Materiaal	Sherwood ref.
2036	Neopreen	10187
2037	Neopreen	9959
2042	Neopreen	18200
2043	Nitrile	9979
2047	Neopreen	10615
2672	Neopreen	17000
3386	Neopreen	19000
3407	Nitrile	12338
3648	Neopreen	22000
3790	Neopreen	15000
3950	Neopreen	10077
4807	Neopreen	8000
4861	Neopreen	27000
4988	Neopreen	9000
5062	Neopreen	18000
5063	Neopreen	26000



De impeller is een belangrijk onderdeel van het koelsysteem van de motor. Deze dient elk jaar, of bij intensief gebruik elke 500 uur vervangen te worden. Ze zijn meestal gemaakt van neopreen rubber, voor goede mechanische eigenschappen (slijtvast). Dit betekent dat dit de beste keuze is voor een koelwaterpomp. Als de impeller wordt gebruikt in een bilgepomp, waarbij deze in aanraking kan komen met olie of brandstof is nitrile rubber een betere keuze. Deze zijn minder slijtvast, maar hebben een betere chemische bestendigheid, waardoor uitzetten van het rubber en daardoor blokkeren van de pomp voorkomen.

DEKSELS

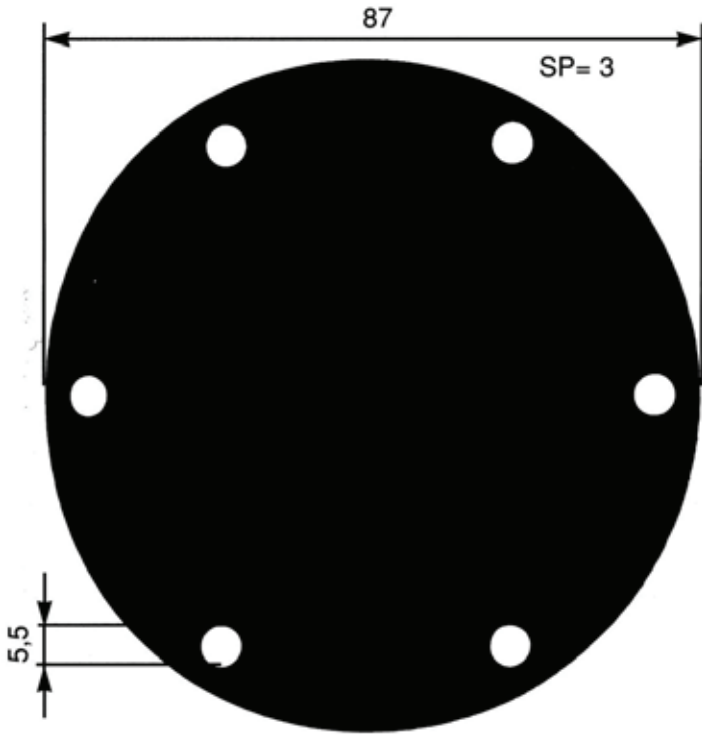

CD2408  
CD3364 con sede O-Ring

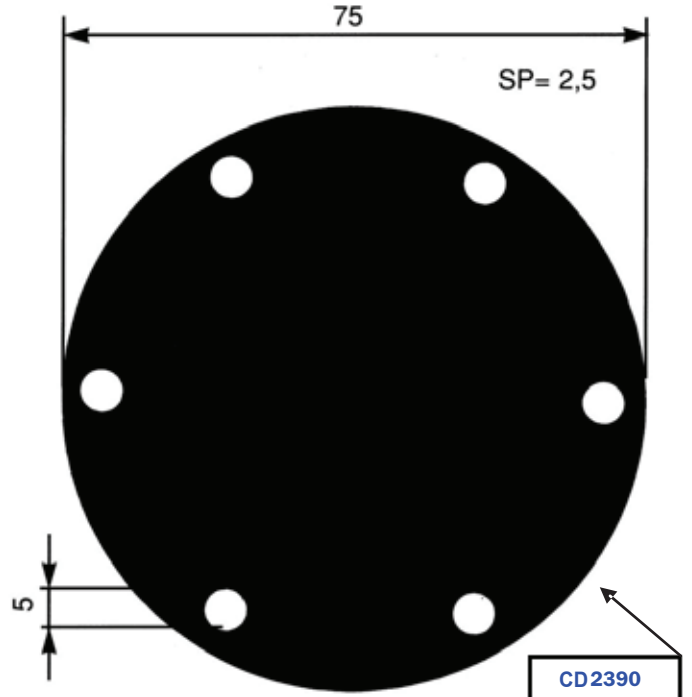

CD2390

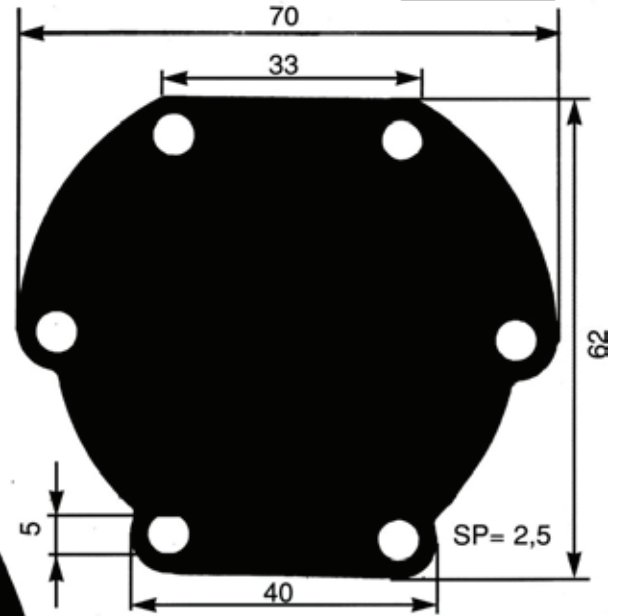

CD2380

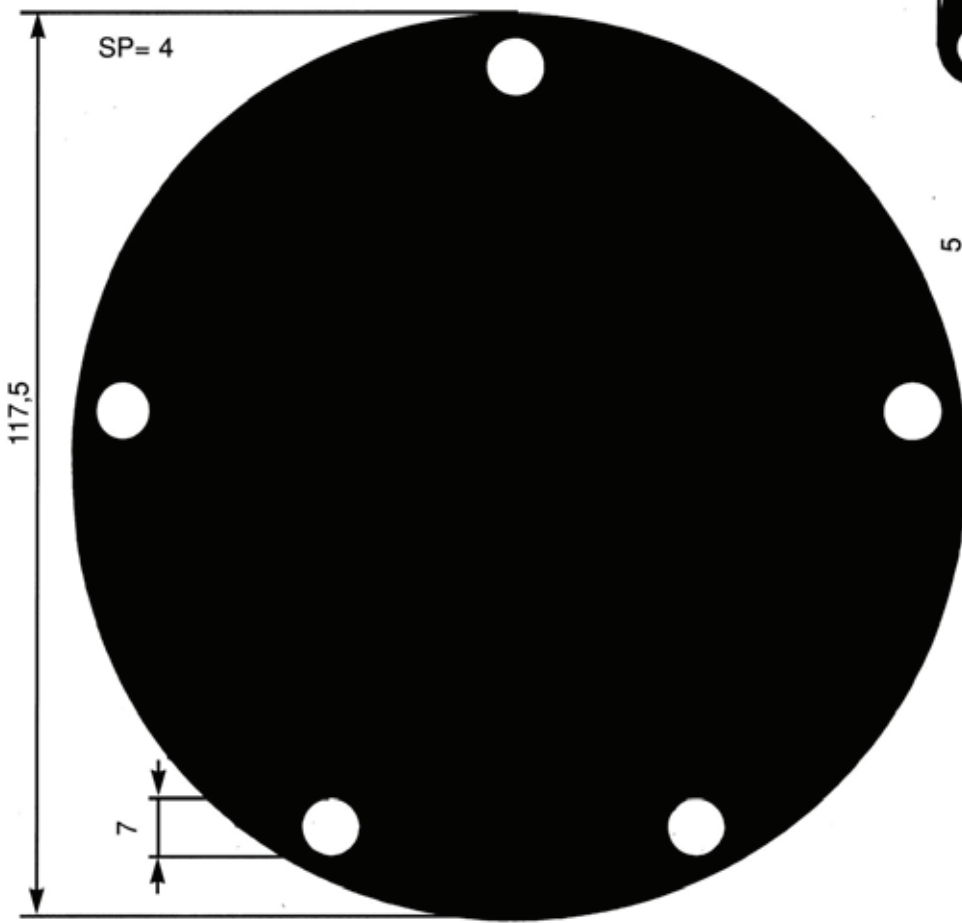

CD 2419  
CD 5115 SP=6 mm

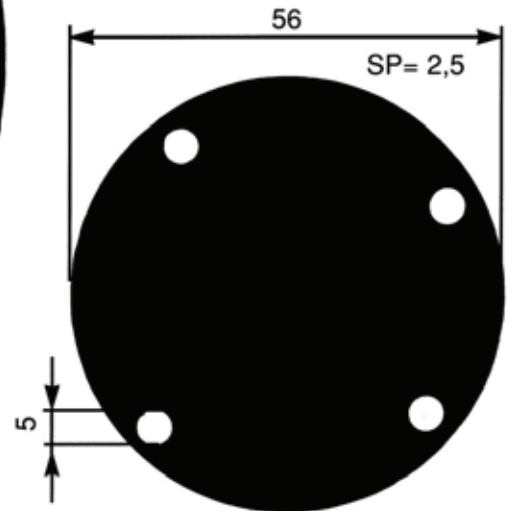

CD 2370

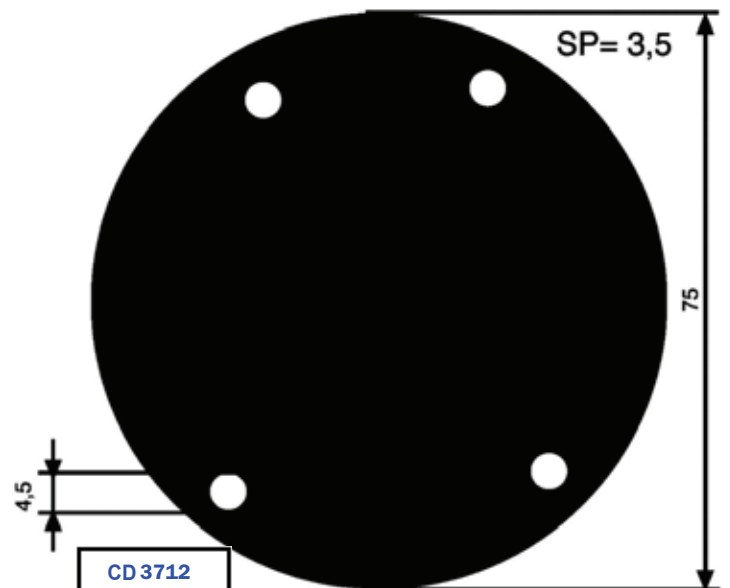
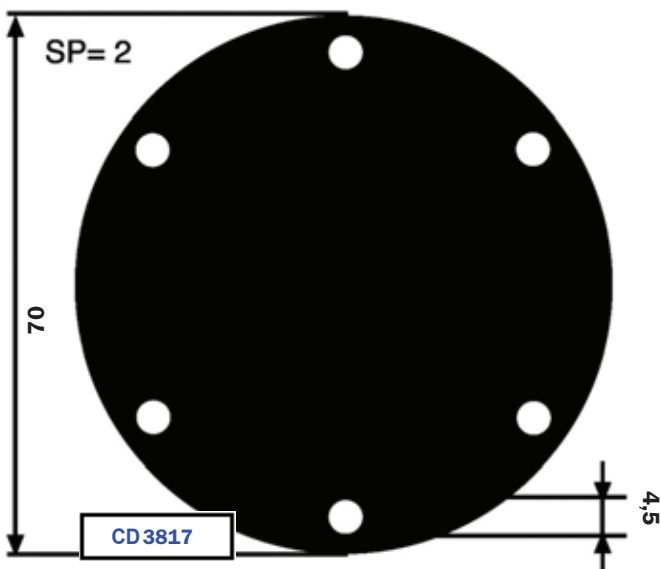
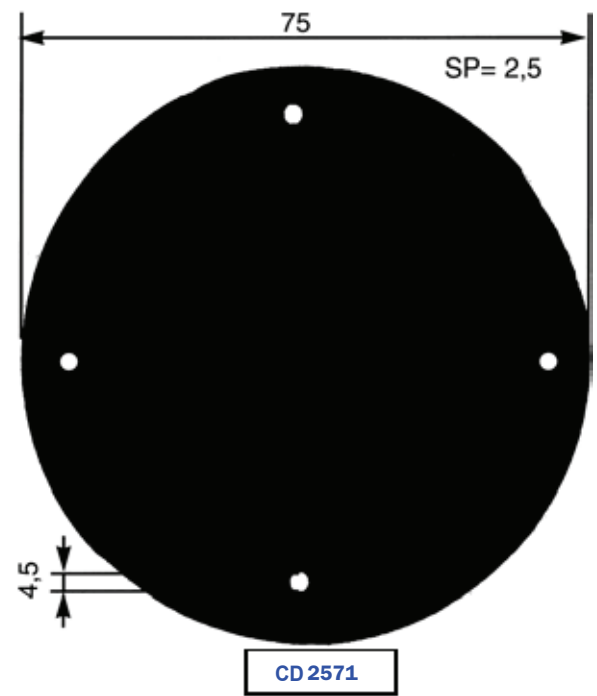
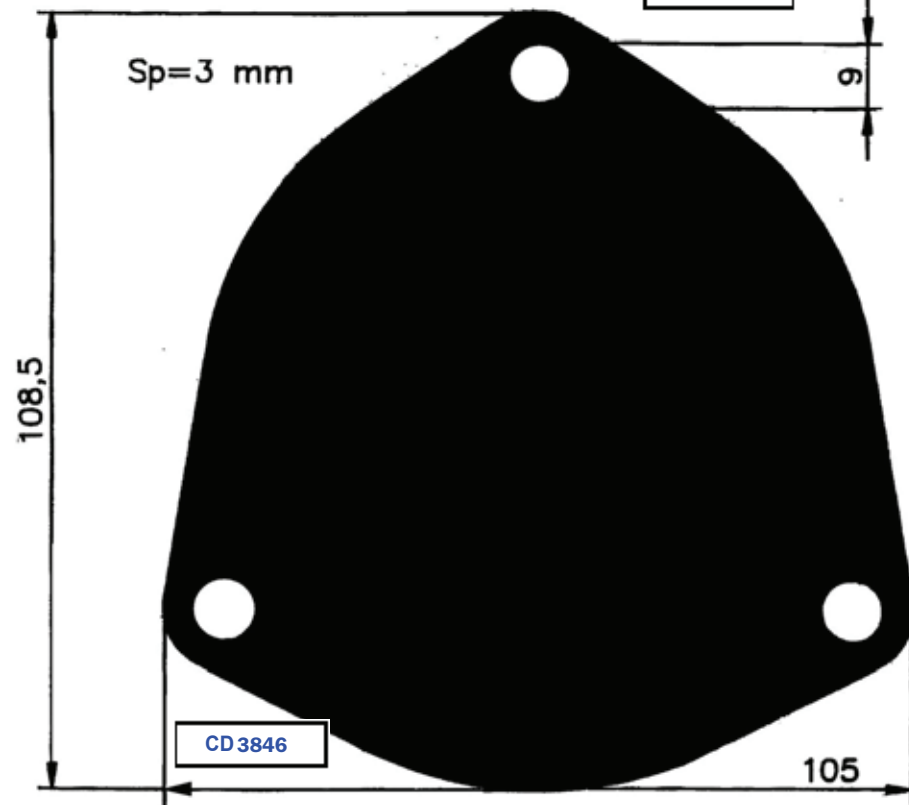
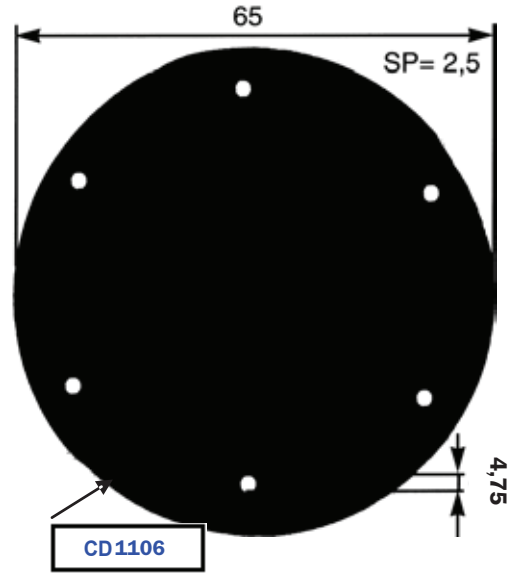
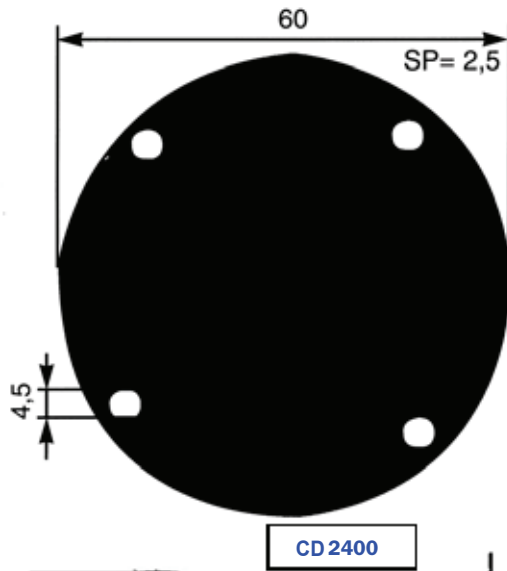
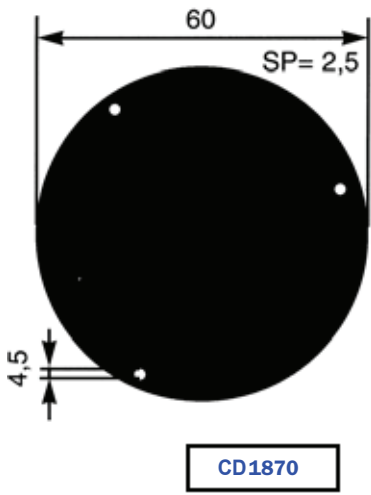

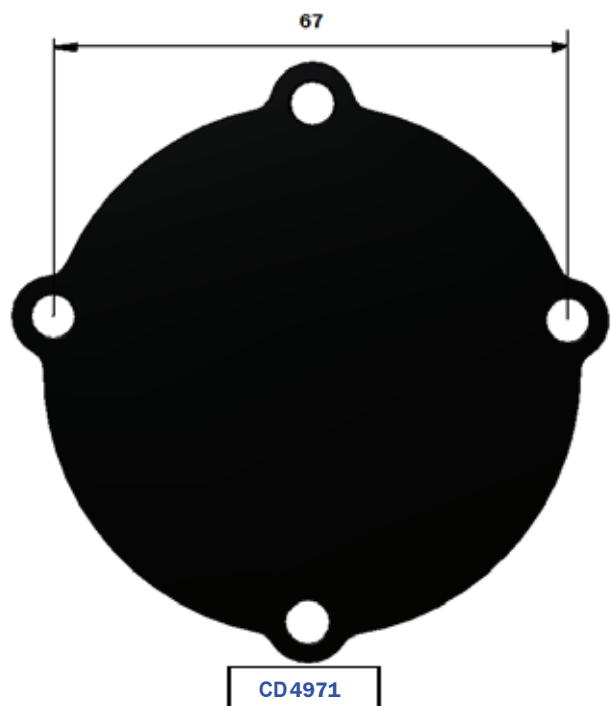
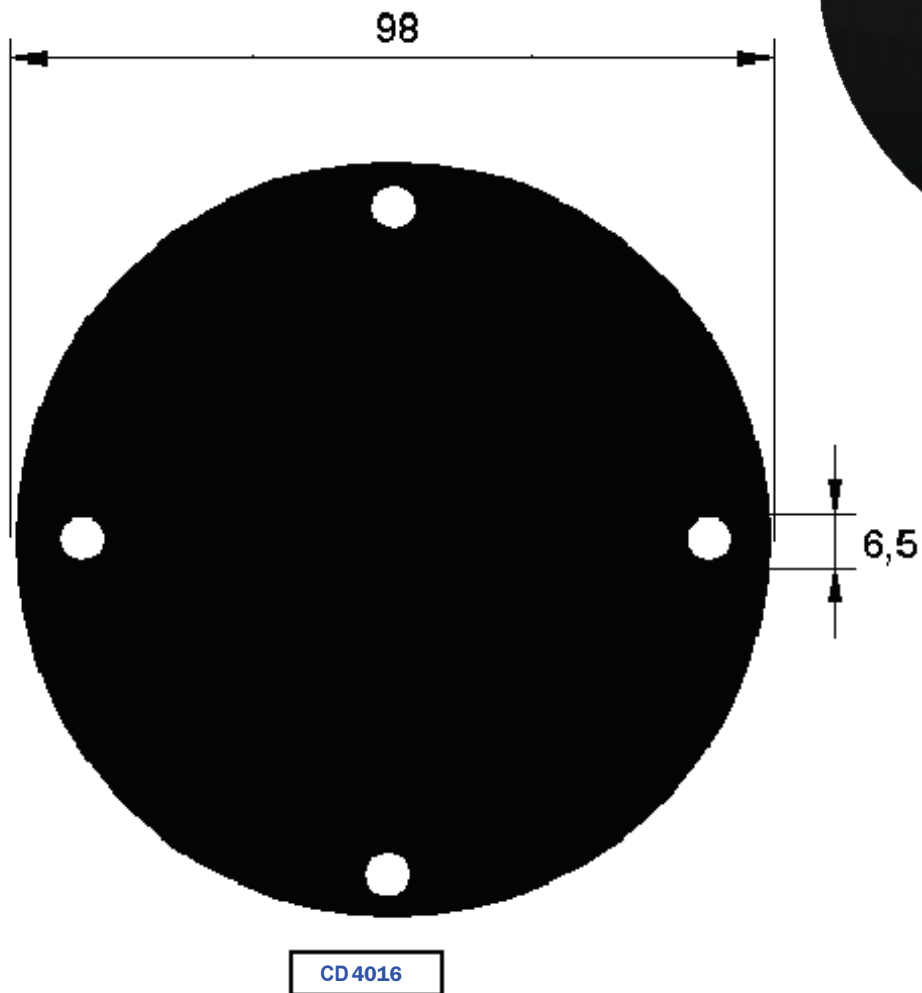
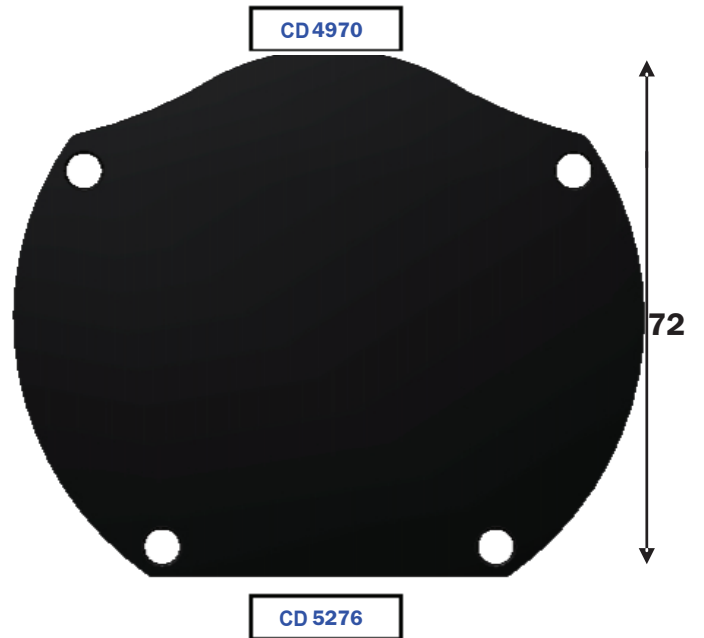
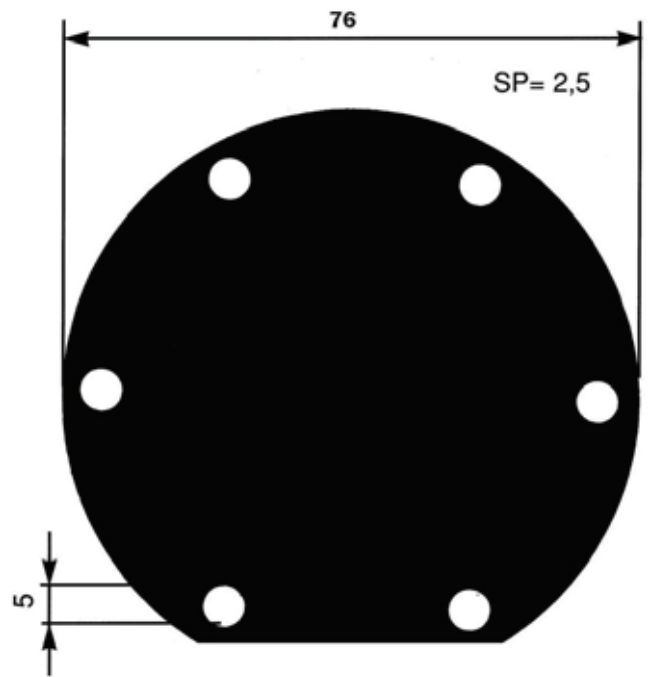
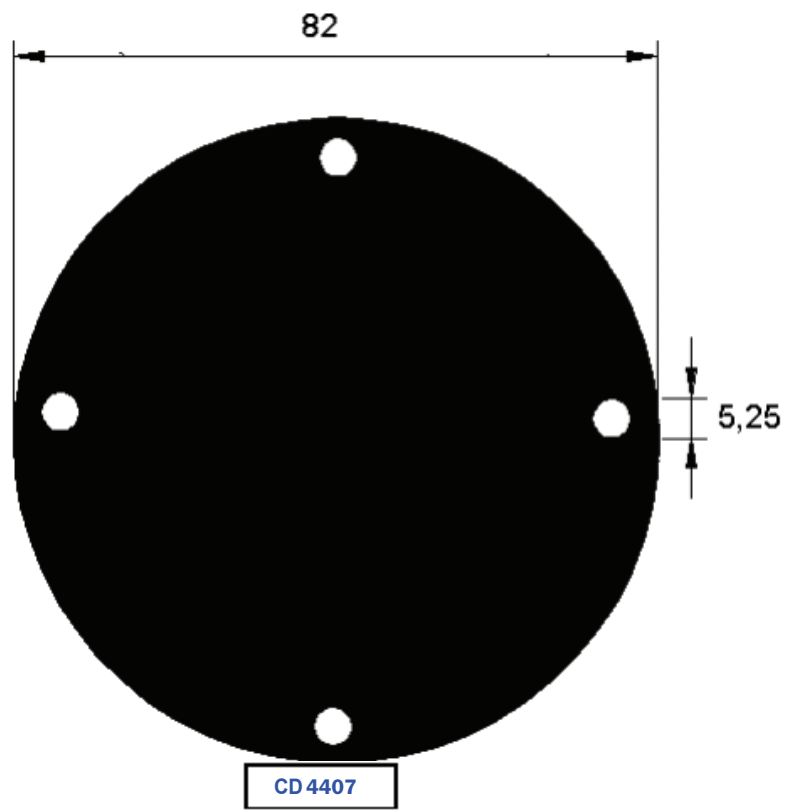

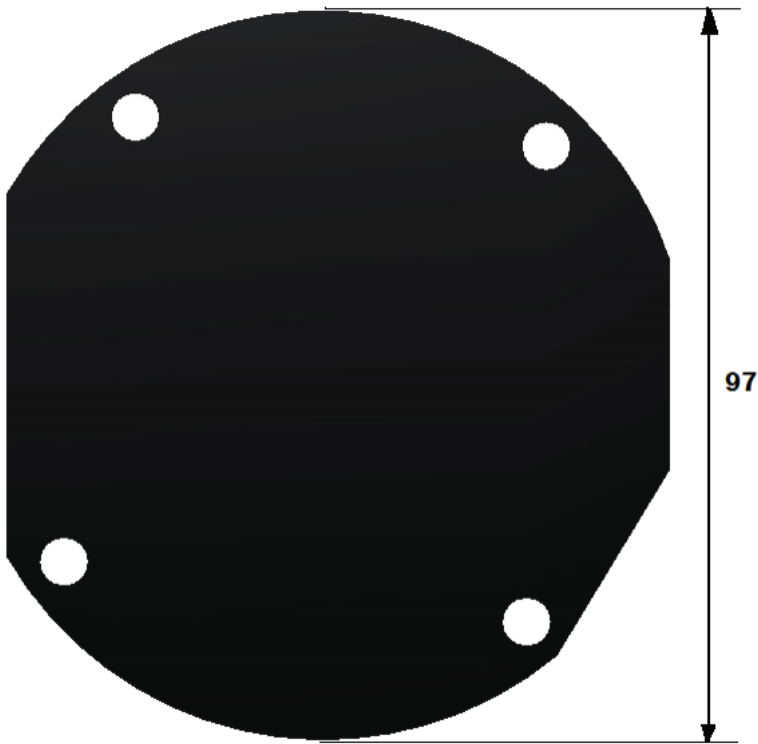

CD5285

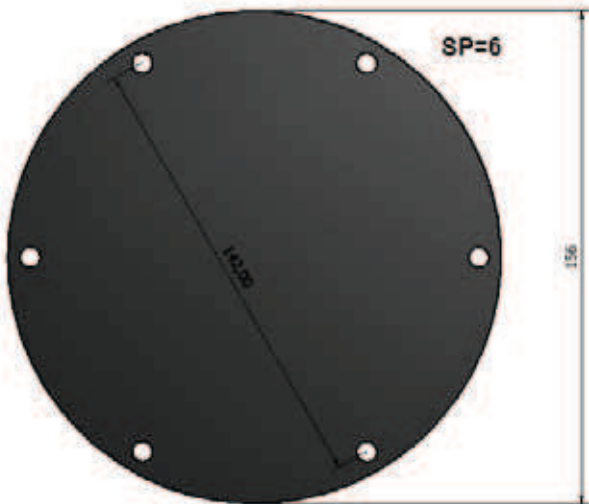

CD5319

NON IN SCALA 1:1

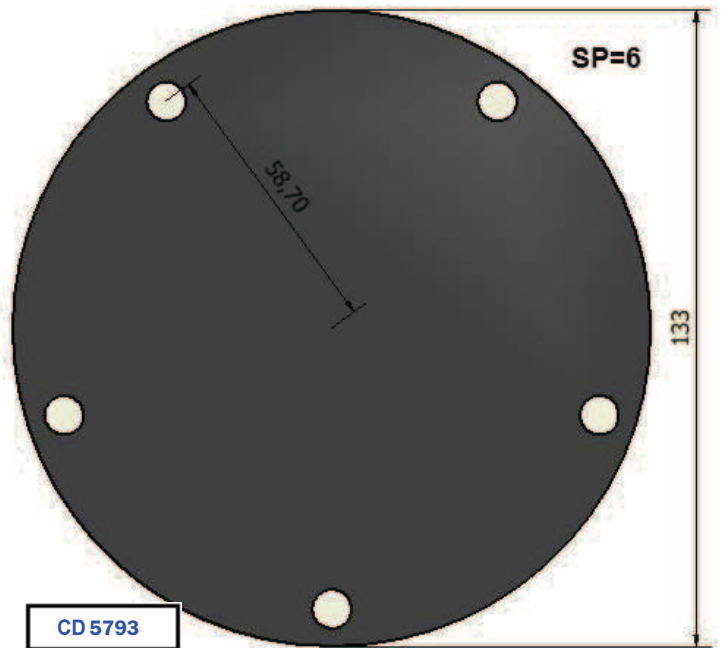

CD 5793

NON IN SCALA 1:1



SLIJTPLATEN

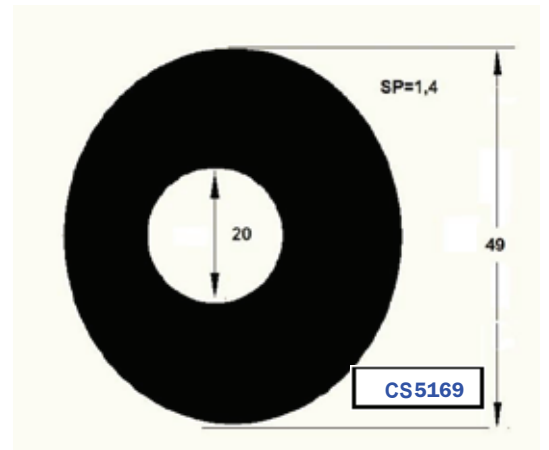
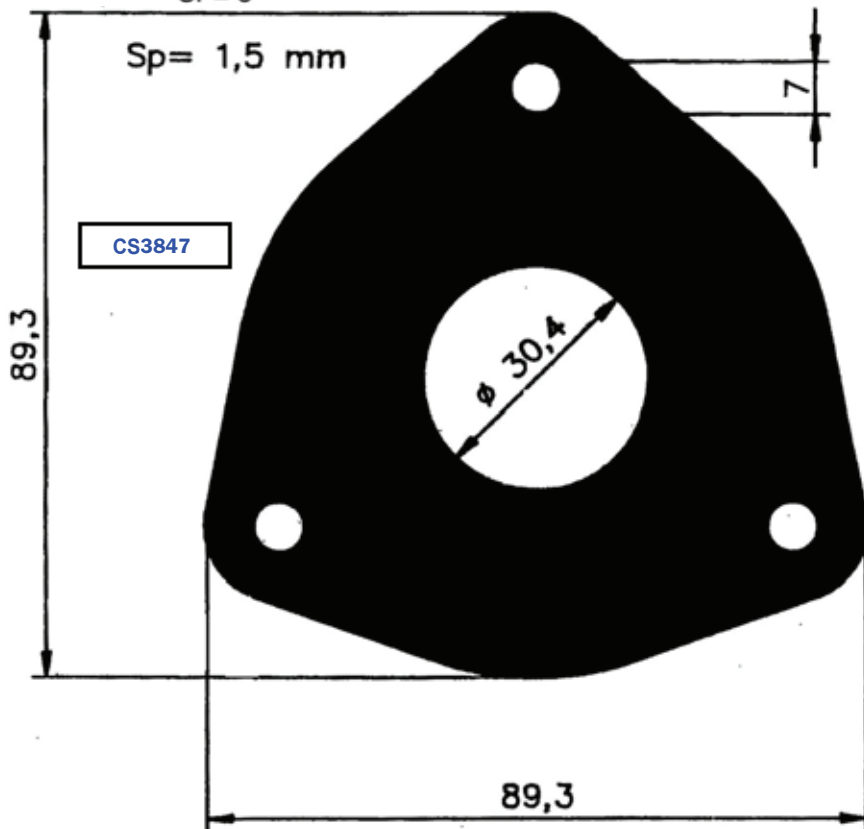
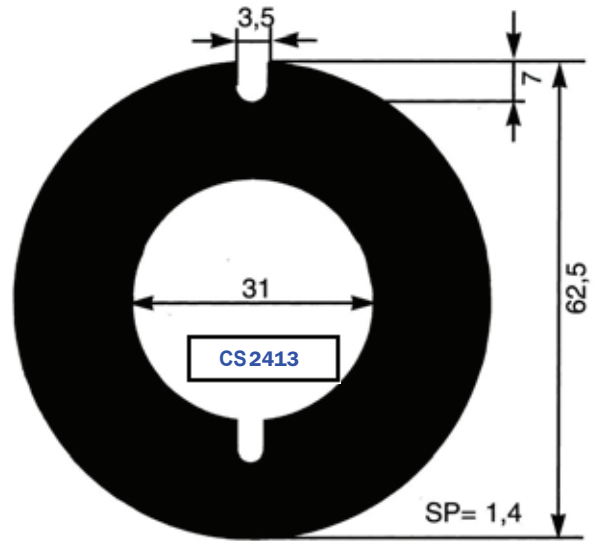
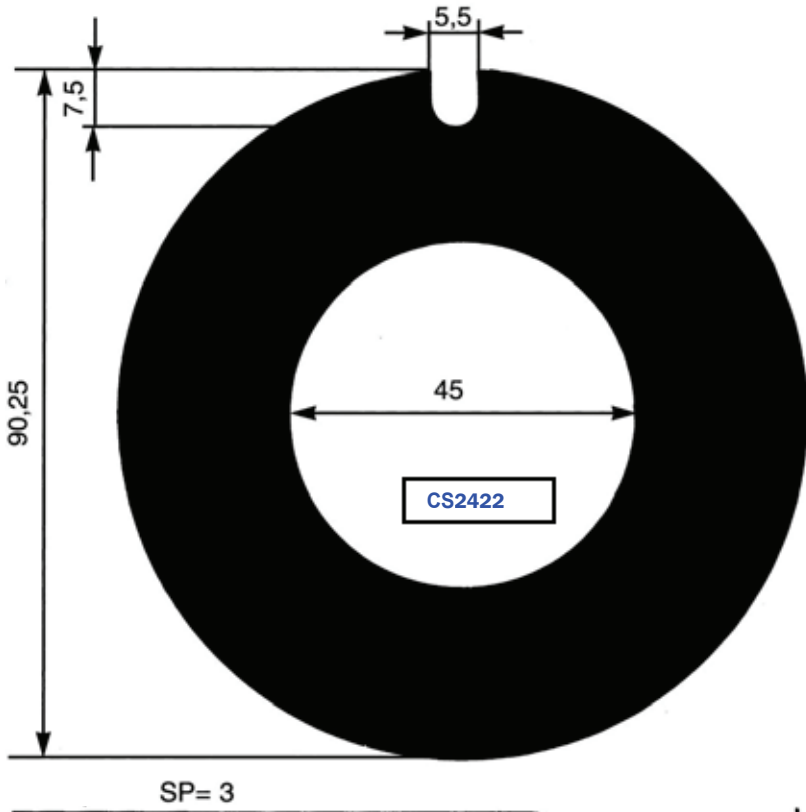
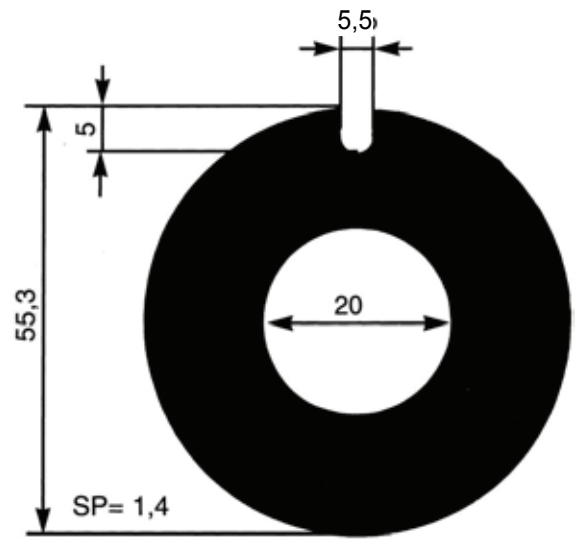
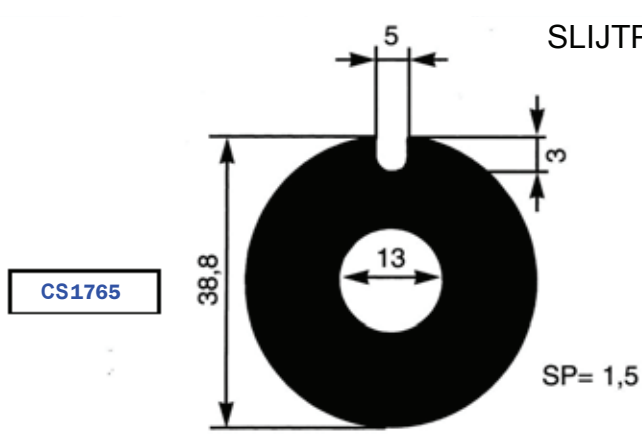

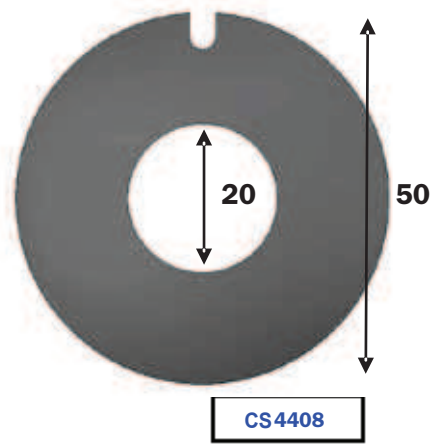
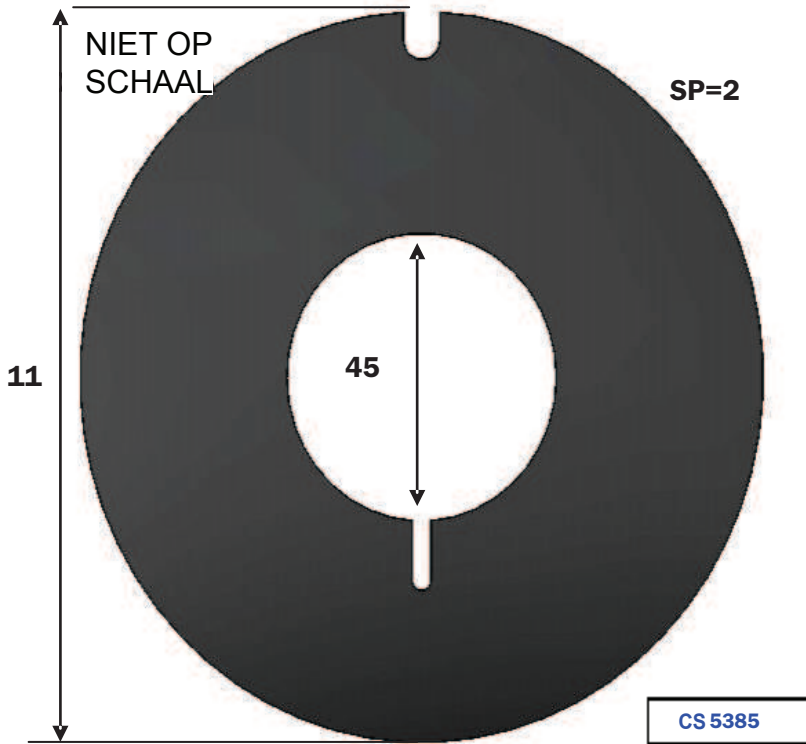
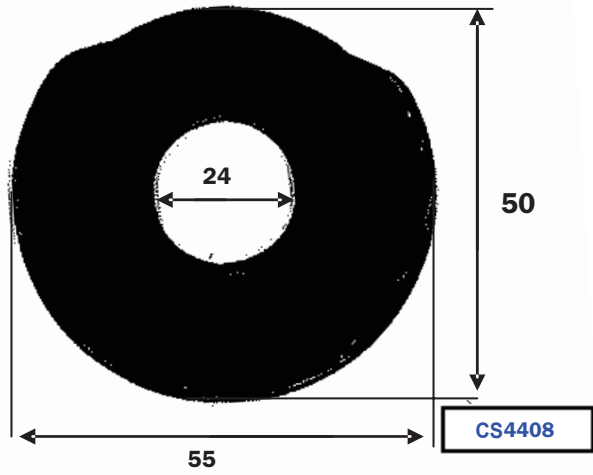
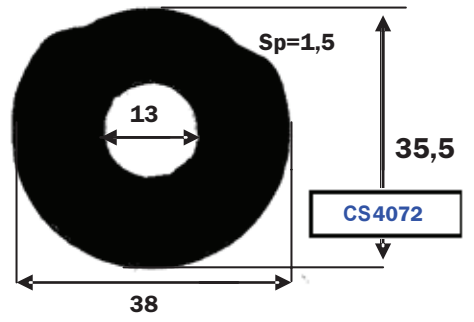
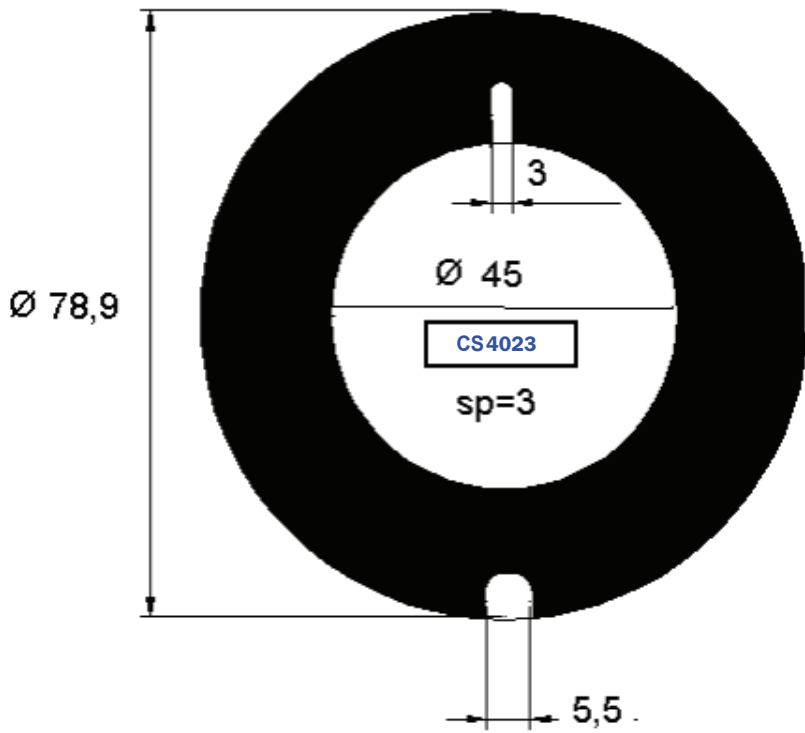

KAMMEN

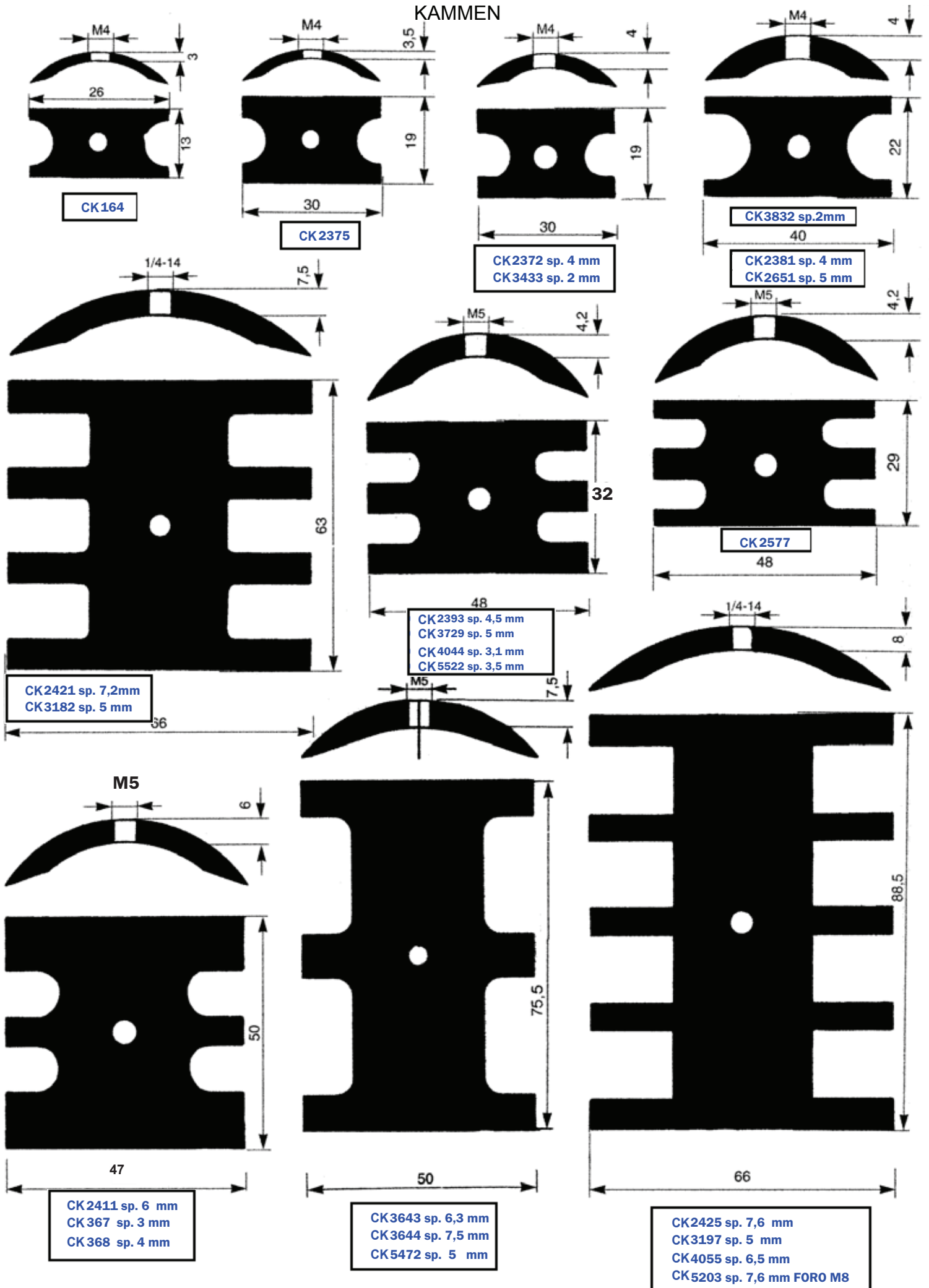

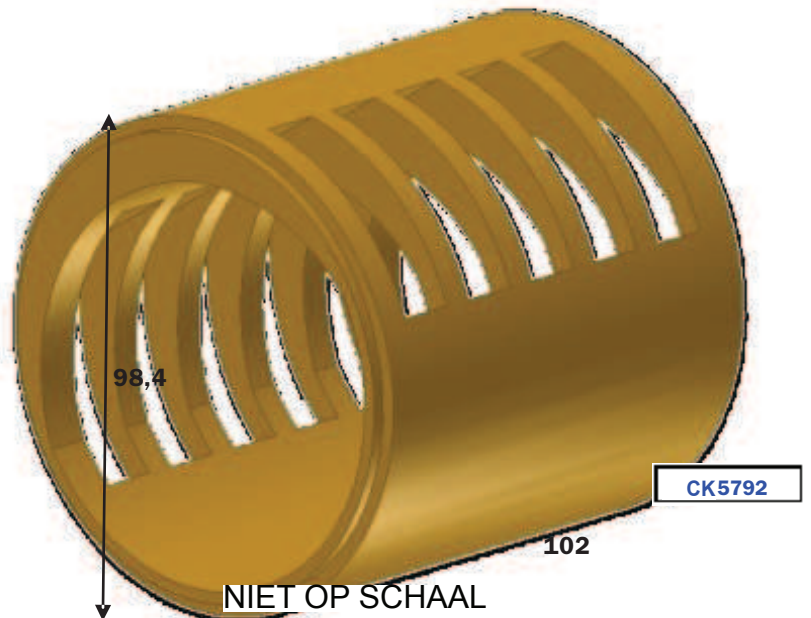
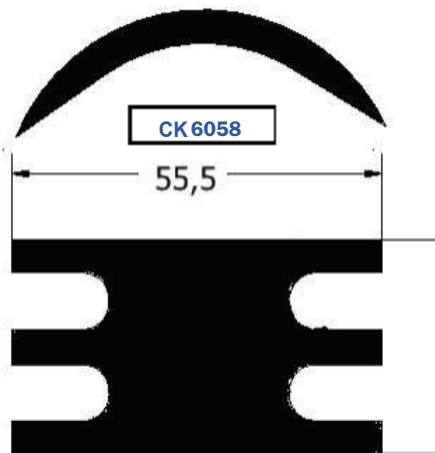
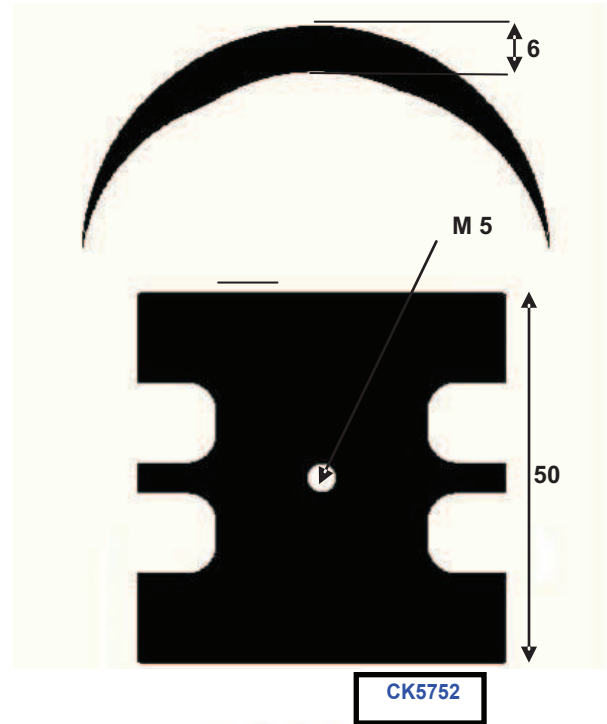
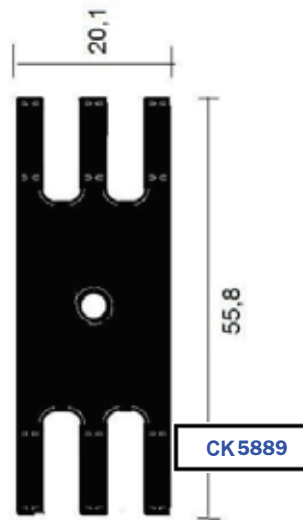
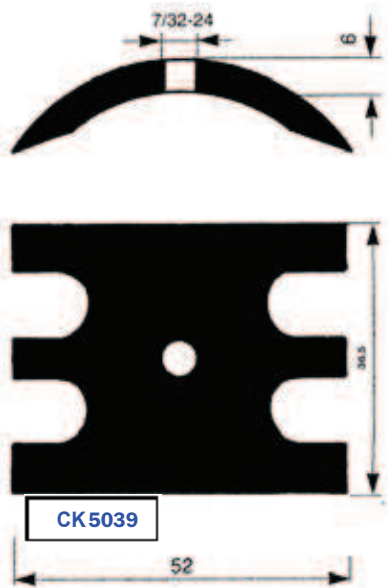
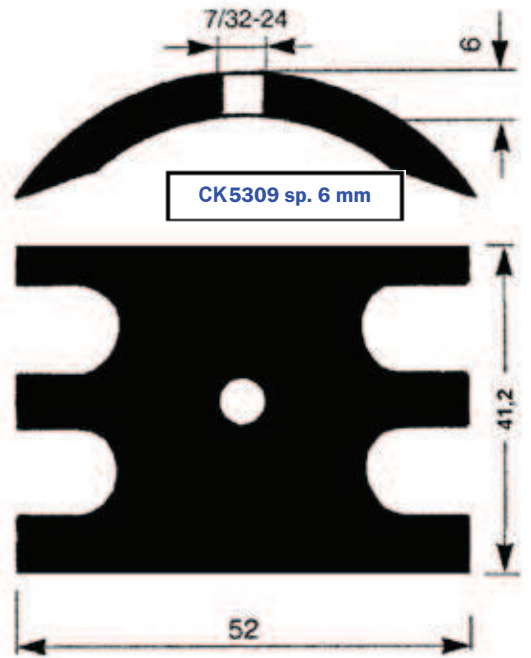
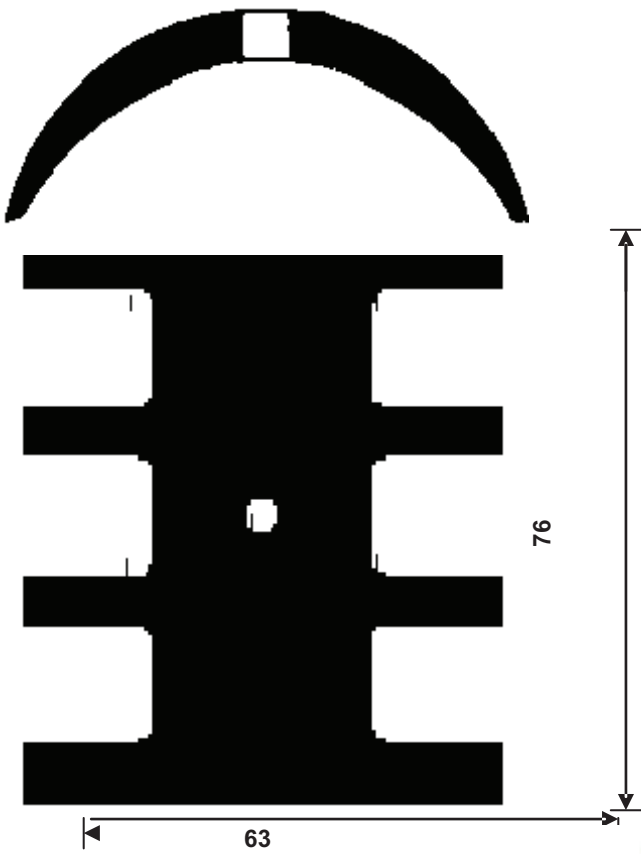

PAKKINGEN

